



OPERATOR'S INSTRUCTION MANUAL

MODEL : **531 000** _____

ENGINE MODEL : _____

SERIAL : _____

ENGINE SERIAL : _____

DATE OF PURCHASE : _____

PURCHASED FROM : _____



⚠️ WARNING ⚠️

THIS PRODUCT IS DESIGNED AND MANUFACTURED TO PROVIDE SAFE AND DEPENDABLE SERVICE IF OPERATED ACCORDING TO INSTRUCTIONS. THE MANUFACTURER PROVIDES THE FOLLOWING INSTRUCTIONS FOR USE AND CARE OF THIS EQUIPMENT AND RELIES UPON THE PURCHASER TO SEE TO IT THAT THESE INSTRUCTIONS ARE MADE CLEAR TO THE PERSONS WHO WILL ACTUALLY BE USING THE EQUIPMENT. FAILURE TO DO SO COULD RESULT IN SERIOUS INJURY OR EQUIPMENT DAMAGE.



INDEX

INTRODUCTION	3
PREPARATION	4
OPERATOR	4
WEAR PROPER ATTIRE	4
ROOF PREPARATION	4
INSPECT ROOF DECK	4
WARNING LINE SYSTEM	4
PLEASE READ BEFORE HANDLING HOIST	5
SPECIAL WARRANTY NOTES	5
SAFETY INSTRUCTIONS	5
ROPE CONDITION	5
HOISTING WHEEL	6
CRACKS	6
CORROSION	6
DEFORMATION	6
PRE-HOISTING CHECKLIST	7
RULES FOR HOISTING	7
RAISING TO ROOF	8
ASSEMBLY	8
SAFETY HAZARDS	9
FALLS	9
BURNS	9
HEAVY LIFTING	9
FIRE/EXPLOSION	10
ELECTROCUTION	10
FALLING OBJECTS	10
FLYING OBJECTS	10
UNGUARDED MACHINERY	10



INTRODUCTION

531 000 - 300 LBS MANUAL SWING HOIST

Thank you for purchasing this quality GRIZZLY product. With proper use and care this hoist will provide many years of reliable service. For the safety of all job-site personnel it is mandatory that the instructions provided for the use and handling of the equipment be read and thoroughly understood by the operators.



CAUTION

INTENDED USE: THIS MACHINE IS INTENDED TO BE USED FOR THE SOLE PURPOSE OF LIFTING AND LOWERING MATERIAL AND SUPPLIES TO AND FROM THE ROOF. ANY OTHER USE OF THIS EQUIPMENT VOIDS THE MANUFACTURER'S WARRANTY AND IS THE SOLE RESPONSIBILITY OF THE OWNER/USER, SHOULD ANY DAMAGE OR INJURY MAY OCCUR.



PREPARATION

OPERATOR

START BY READING AND FULLY UNDERSTANDING OPERATING INSTRUCTIONS. IF SOMETHING IS NOT UNDERSTOOD, HAVE SOMEONE ELSE READ AND EXPLAIN THE INSTRUCTIONS TO THE OPERATOR OR CALL THE MANUFACTURER FOR INFORMATION. AN UNINFORMED OPERATOR CAN SUBJECT HIMSELF AND OTHERS TO DEATH OR SERIOUS INJURY.

WEAR PROPER ATTIRE

Safety glasses are recommended and must be worn if any roof cutting or scraping is being done in the vicinity. Safety glasses and or face shield are also necessary when working with hot stuff.

Wear properly fitting clothes. Tight clothing can restrict movement and slow down reaction time in a dangerous situation.

Loose fitting clothing can be dangerous and cause serious injury if it gets caught in moving mechanical parts. Wear a long-sleeved shirt, buttoned at the cuffs, safety shoes, and pants without cuffs, and knit wrist type gloves.

A hard hat must be worn by operator when working on a job site.

ROOF PREPARATION

INSPECT ROOF DECK

Before allowing equipment and personnel access to roof, make certain roof is strong enough to support the weight. Check load limits of deck with owner, builder or architect. Clear the work area of all potentially dangerous obstacles that could cause personal injury to the operator or others. Keep unauthorized people away from construction area. Check to see that all roof openings are guarded to protect against falls.

WARNING LINE SYSTEM

When operating parallel to roof edge warning line system must be at least six feet from edge. When operating perpendicular to edge warning line must be ten feet from roof edge.



PLEASE READ BEFORE HANDLING HOIST

WARNING; THESE HOISTS ARE NOT FOR TRANSPORTING OR HANDLING OF PERSONS. NO PERSONS SHALL BE ALLOWED TO RIDE ON MATERIAL HOISTS.

SPECIAL WARRANTY NOTES

Manufacturer is NOT responsible for warranty if equipment is subject to unusual, improper use or abuse by person(s) using the equipment, or for purposes for which it was not intended for. Warranty is further void if any modifications are made to the equipment by the owner. Collisions, overturn, dropping, water damage, or damage to equipment after being shipped by manufacturer, also voids the warranty.

SAFETY INSTRUCTIONS

WARNING; DO NOT SET UP HOIST FOR LIFTS OVER 100 FEET. DO NOT SET UP HOIST ON SLOPED ROOFS.

1. After the hoist is assembled, make sure that all nuts and bolts on the frame are properly fastened. If any are loose, make sure that they are tightened before operating the hoist to ensure the operator's safety and the safety of others.
2. The fence located on the front frame must be in place to protect the operator from accidentally falling off the roof edge while operating the hoist.
3. Make sure to always have enough counterweights on the rear weight base. It is recommended that you use 1-1/2 times the weight that you are lifting. After placing counterweights secure them to the hoist frame using a wire cable or chain to prevent them from being removed or falling off of base in the event of sudden impact load. Example: If you are lifting 300 LBS of material, use 450 LBS of counterweight.

WARNING; NEVER USE ROOFING MATERIAL THAT WILL BE USED IN THE ROOFING PROCESS AS COUNTERWEIGHTS. ALWAYS USE PERMANENT COUNTERWEIGHTS SUCH AS GRIZZLY #597 000 STEEL COUNTERWEIGHTS.

4. Always keep in mind the maximum rated load of the hoist you are using.

WARNING; NEVER ATTEMPT TO LIFT MORE THAN THE MAXIMUM RATED LIFT LIMIT, DAMAGE TO THE HOIST AND/OR INJURY TO THE OPERATOR COULD RESULT.

ROPE CONDITION

Rope must be in good condition with no broken strands, no rotting, and no knots between the ends of the rope. Use only $\frac{3}{4}$ " or 1" manila rope.



HOISTING WHEEL

Check gin wheel for wear or damage. Check for cracks and bends in the wheel and housing. Check center pin for wear or possible damage. Never lift with a damaged wheel. Make sure center pin is securely locked. Hoisting wheel must spin freely. Any binding could indicate a bearing failure and should be replaced.



CRACKS

Any cracks in the Hand hoist structure make the product unsafe to operate. If cracks exist, replace the unit or have repairs made. Welding repairs must be made by a qualified welder. The hoist must be tested by a qualified operator prior to use on the job to evaluate any possible deficiencies.

CORROSION

An examination must be made to determine whether corrosion exists on any part of the hoist that may result in a component failure when hoist is operated. If so, that portion of the structure must be replaced. IF THERE IS ANY DOUBT, DO NOT OPERATE THE HOIST.

DEFORMATION

Any damage to frame members such as bends or kinks will significantly weaken the structure and reduce the working load limits of the hoists, making it unsafe to use at rated loads.



PRE-HOISTING CHECKLIST

1. Inspect all nuts/bolts and pins, tighten or replace as necessary.
2. Be certain that the proper amount of counterweights is securely in place before hoisting operation begins.
3. Be certain that hoisting operation will clear all power lines and obstructions. Failure to do so may cause severe injury or electrocution.
4. Make sure all safety devices such as guards and operator fences are in place.
5. Make sure that hoisting area is clear of personnel at all times.
6. Learn and use hoisting signals and discuss them prior to hoisting: an alternative means of communication is a hand-held walkie-talkie where working conditions warrant.

RULES FOR HOISTING

- Only trained personnel should operate hoist.
- This hoist requires a minimum of two operators, one on the ground and one on the roof.
- Always follow pre-hoisting checklist before operating.
- Make sure the hoisting area is clear of power lines. Consult Power Company before you work near power lines. Take appropriate measures before you start. Insulating power lines for your protection from electrocution is a service that all utility companies offer their customers.
- Make sure hoisting area is clear of personnel at all times. Place barricades or markers if necessary.
- Do not exceed the rated capacity of any hoisting component.
- Check counterweight before hoisting, every time you use the hoist.
- When attaching line to the load use a hoist hook with a latch or if no hook is used, tie a bowline knot to the load.
- Make sure load is secure before lifting.
- Never stand under the load or in the line of force of the load.
- Do not normally hoist over open doorways. If you must, secure the area with barricades and markers inside and outside.
- Use hand over hand method to move the rope.
- Stand a few feet to the side of the load's path.
- Do not raise or lower load from the roof, hoisting must be made from the ground.
- Coil excess rope in such a way that it will not become tangled.
- Use tag lines to control load.
- Never attach the rope to any part of your body or to a vehicle.
- Never attach a load that is diagonal to the hoist, nor drag a load along the ground.
- Never lift a load that is more than half your weight.
- Never exceed the load limit of the hoist.



- Check the hoist periodically during operation.
- When lowering, keep descent smooth and under control, avoiding sudden stops. Never let load “free-fall”.
- Never assume you will find the hoist in the same condition that you left it. Take a few minutes to “look it over” before proceeding to hoist.
- Repairs should be made by authorized trained personnel.

RAISING TO ROOF

The hand swing hoists are shipped in sections for ease of transportation and assembly.

1. Position the sections at the base of the wall below the site of operation.
2. Use two or more men on the roof for lifting and one man on the ground with tag line to guide sections up, keeping them clear of the wall.
3. Raise the rear leg assembly to the roof and place it well back from the roof edge (approximately 25 feet)
4. Raise the front leg assembly and place it in front of the rear leg assembly, still keeping it at least 10 feet from the roof edge.
5. Raise the swing boom and place it 10 feet from roof edge.

ASSEMBLY

1. Slide the rear leg into the front leg pins and secure.
2. Place the swing boom on top of the front leg and secure.
3. Move the hoist carefully to the roof edge.
4. Place proper counterweights on the base of the rear leg.
5. Inspect hoist as per pre-hoisting check list instructions.

Please refer to the parts blow-out at the end of this manual.



SAFETY HAZARDS

Safety hazards are not always obvious to workers. Unlike exposure to health hazards, where illness or injury develop slowly, safety hazards usually result in immediate injury or death.

Broken bones, cuts bruises, sprains, burns and loss of limbs, eyesight and hearing are the kinds of injuries caused by safety hazards.

The rate of occupational injuries in roofing, in fact, ranks in the top ten of all major occupational groups.

FALLS

Falls are the number one cause of serious injury and death to roofers. An estimated 10 percent of all roofing accidents result from falls off roof edges, through roofing openings or off ladders, more than half of the non-fatal accidents result in serious injury.

Unprotected and unguarded roof edges and roof openings create extremely hazardous conditions.

Ladders with cracked, loose or missing steps: with side rails broken or cracked and not attached firmly to the steps; with broken, loose or missing locks, or coated with grease, oils or hardened bitumen can lead to serious injury. Ladders should always be inspected to make sure they're properly maintained and constructed and that they're long enough to extend three feet above the roof's surface.

Improperly balanced or unstable hoists overturn and will often carry the worker along. Rolls of roofing felt should never be used as counterweight. Workers should know the load capacity; it should be posted.

BURNS

Skin contact with hot asphalt and hot coal tar pitch usually results in second and third degree burns. They usually involve deeper portions of the skin and are easily infected.

An estimated 16 percent of all injuries are burns from hot stuff. The major causes of burns have been from:

Kettle flashes

- Kettle splashes from dropping pieces of coal pitch or asphalt into the kettle
- Slips and trips while carrying hot bitumen in open containers
- Splashes involving transfer operations like from the hot pipe outlet to a hot lugger, from a hot lugger to a mop cart or a pail, or from the kettle to a pail.

HEAVY LIFTING

Sprains and strains, a majority of which involve the back, are the most common roofing injury and one of the most severe. Almost 30 percent of these injuries result in 10 or more days away from work.



FIRE/EXPLOSION

Two conditions must be met in order for fires and explosions to occur. First, there must be an ignition source, a welding arc, spark, cigarette, flame or simply a hot spot as in a kettle or tanker. Secondly, there must be the right mixture of vapours (from asphalt, pitch, solvents) and oxygen.

For kettles and tankers, fire/explosion conditions arise when:

- oversized burners are used to fire the kettle, causing localized overheating of the heating tubes creating a hot spot
- the temperature of the bitumen is brought up to the desired operation temperature too quickly allowing the level of bitumen to drop to the level of the firing tubes, allowing excessively high surface temperatures
- heating the bitumen to its flash point (for asphalt, about 525°-540°; for pitch, about 450°-475°)
- the temperature of the bitumen is hot enough to reach the auto-ignition level
- in tankers, the vent pipe is clogged or plugged so that flammable vapours can build up to explosive levels

Many solvents evaporate quickly at roof temperatures. Explosive mixtures of vapours can be readily formed within confined spaces like high parapet walls, in atriums or in any space where little or no ventilation exists. And any kind of spark or flame can ignite the vapours.

ELECTROCUTION

Low voltage electricity can cause shock, muscle contractions, breathing difficulty, irregular heartbeat, severe burns and death. The route that the current takes through the body affects the degree of injury. Current flowing from one finger to another would not pass vital organ, while from one hand to another would pass through the heart and lungs.

Electrical tools should be properly grounded. The electrical cord should end in a three-prong grounding contact, or the wires should be enclosed in a metal case with a special grounding attachment.

Employers are required to provide ground fault circuit interrupters for all outlets on construction sites that are not part of the permanent wiring of the building. This is actually a fast-acting circuit breaker, which can shut off electricity in a fraction of a second.

Aluminum or other metal ladders pose a serious electrical hazard around electrical equipment and energized lines.

FALLING OBJECTS

Tools, bricks, materials, buckets, boxes, pallets or almost anything dropped from a sufficient height can cause severe damage. Head injuries, one of the highest compensated injuries to workers, often include brain damage. Workers need protective head gear when working beneath people, tools and equipment.

FLYING OBJECTS

Objects can be projected by machines, from welding or grinding operations and can be windblown. Tear-off operations, where power cutters, power brooms and power spudders are generally used, are the major source of flying substances. The part of the body most often injured is the eyes.

UNGUARDED MACHINERY

Exposed blades and chains on powered machinery like hoists and roof cutters can severely lacerate and crush parts of the body. Guards should always be fitted over moving parts to protect workers.



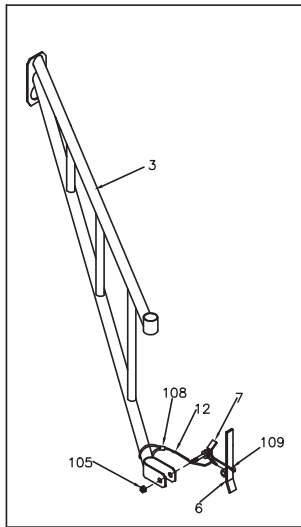

ITEM	NO.	QTY.	DESCRIPTION
1	531001	1	BACK LEG
2	531002	1	COUNTERWEIGHT BASE
3	531003	1	BOOM
4	531004	1	MAIN SUPPORT
5	531005	1	FENCE
6	531006	1	STOP LATCH
7	531007	1	LOCK HANDLE
8	531008	1	CONNECTING PIPE
9	531009	2	LOCK HANDLE
10	531010	1	SUPPORT
11	923505	2	BUSHING
12	531012	1	STEEL CABLE
13	531050	1	BOOM,ASSEMBLY
14	940009	2	PLASTIC CAP
100	910258	5	BOLT,HEX.
101	910260	2	BOLT,HEX.
102	910262	1	BOLT,HEX.
103	912005	6	WASHER
104	912505	6	LOCK WASHER
105	913511	3	LOCK-NUT
106	913011	6	NUT,HEX.
107	940161	1	SPRING LOCK PIN
108	940039	1	OVAL SLEEVES
109	940048	1	STOP SLEEVES
110	910051	1	BOLT,HEX.
111	913503	1	LOCK-NUT

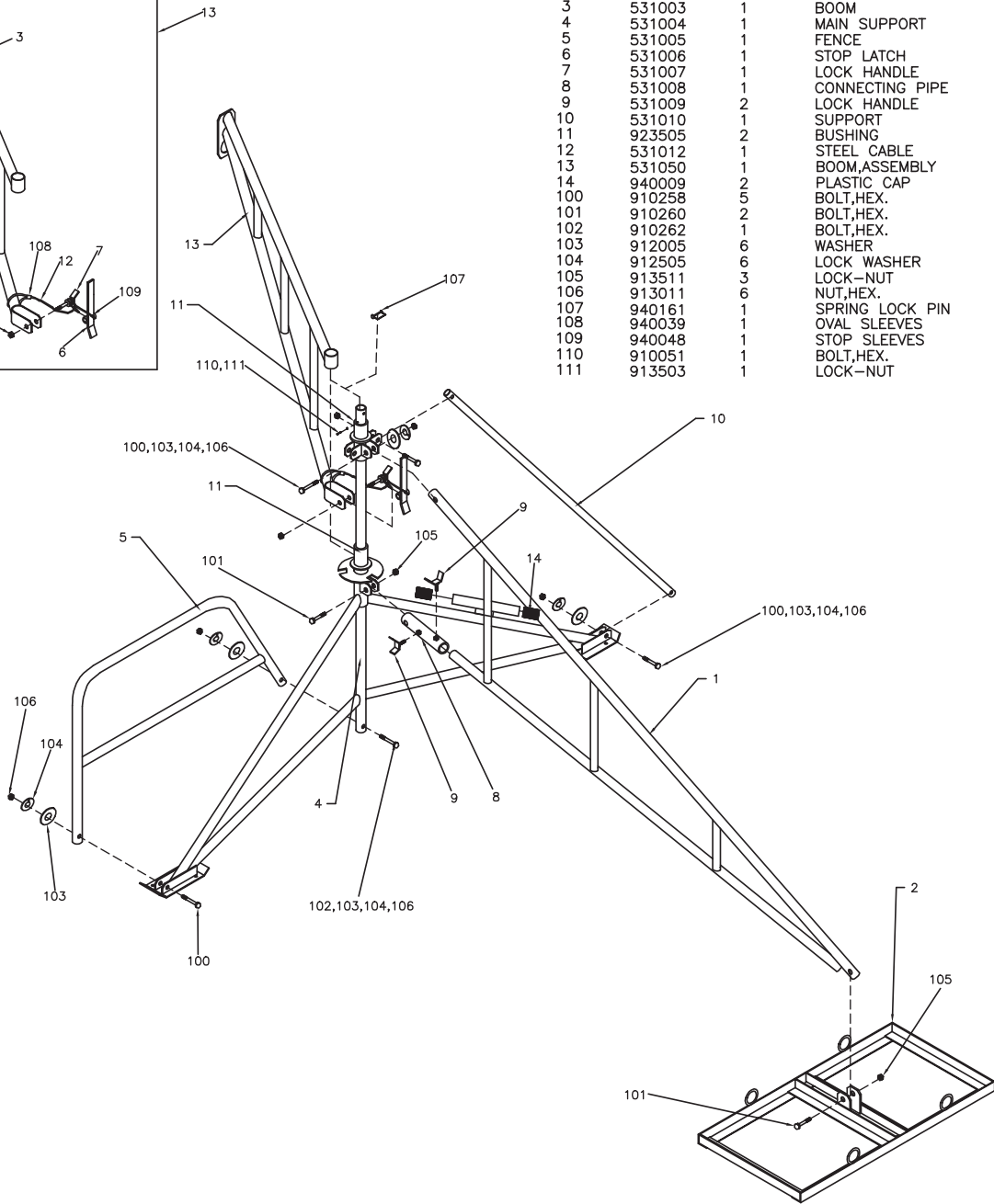

DATE:	12.08.1998	MANUAL SWING HOIST
REV.:	06.01.2019	
EQUIPEMENT GRIZZLY EQUIPMENT		531000

