



# OPERATOR'S INSTRUCTION MANUAL

MODEL : 220 000 / 221 000

ENGINE MODEL : \_\_\_\_\_

SERIAL : \_\_\_\_\_

ENGINE SERIAL : \_\_\_\_\_

DATE OF PURCHASE : \_\_\_\_\_

PURCHASED FROM : \_\_\_\_\_



## ⚠️ WARNING ⚠️

THIS PRODUCT IS DESIGNED AND MANUFACTURED TO PROVIDE SAFE AND DEPENDABLE SERVICE IF OPERATED ACCORDING TO INSTRUCTIONS. THE MANUFACTURER PROVIDES THE FOLLOWING INSTRUCTIONS FOR USE AND CARE OF THIS EQUIPMENT AND RELIES UPON THE PURCHASER TO SEE TO IT THAT THESE INSTRUCTIONS ARE MADE CLEAR TO THE PERSONS WHO WILL ACTUALLY BE USING THE EQUIPMENT. FAILURE TO DO SO COULD RESULT IN SERIOUS INJURY OR EQUIPMENT DAMAGE.



# INDEX

<b>INTRODUCTION</b>	<b>3</b>
<b>PREPARATION</b>	<b>4</b>
OPERATOR	4
<b>WEAR PROPER ATTIRE</b>	<b>4</b>
<b>ROOF PREPARATION</b>	<b>4</b>
INSPECT ROOF DECK	4
WARNING LINE SYSTEM	4
<b>HOISTING MACHINE TO ROOF</b>	<b>5</b>
INSPECT THE HOIST	5
CONNECTING TO LIFT RINGS	5
<b>SAFETY PRECAUTIONS</b>	<b>6</b>
<b>OPERATION</b>	<b>7</b>
BEFORE OPERATION	7
<b>MAINTENANCE</b>	<b>8</b>
<b>SAFETY HAZARDS</b>	<b>8</b>
FALLS	8
BURNS	8
HEAVY LIFTING	8
FIRE/EXPLOSION	9
ELECTROCUTION	9
FALLING OBJECTS	9
FLYING OBJECTS	9
UNGUARDED MACHINERY	9
<b>LIFTING CERTIFICATE - 220 000 (FRENCH ONLY)</b>	<b>10</b>
<b>LIFTING CERTIFICATE - 221 000</b>	<b>11</b>



## INTRODUCTION

### 220 000 - VOYAGER 1 / 221 000 - VOYAGER 2

Thank you for purchasing this quality GRIZZLY product. With proper use and care, the voyager will provide many years of reliable service. For the safety of all job-site personnel it is mandatory that the instructions provided for the use and handling of the equipment be read and thoroughly understood by the operators.



#### CAUTION

**INTENDED USE: THIS MACHINE IS INTENDED TO BE USED ON FLAT, LEVEL ROOFS ONLY FOR THESE APPLICATIONS; PROPANE TANK AND TORCH CARRIER.  
ANY OTHER USE OF THIS EQUIPMENT VOIDS THE MANUFACTURER'S WARRANTY AND IS THE SOLE RESPONSIBILITY OF THE OWNER/USER, SHOULD ANY DAMAGE OR INJURY OCCUR.**



## PREPARATION

### OPERATOR

START BY READING AND FULLY UNDERSTANDING OPERATING INSTRUCTIONS. IF SOMETHING IS NOT UNDERSTOOD, HAVE SOMEONE ELSE READ AND EXPLAIN THE INSTRUCTIONS TO THE OPERATOR OR CALL THE MANUFACTURER FOR INFORMATION. AN UNINFORMED OPERATOR CAN SUBJECT HIMSELF AND OTHERS TO DEATH OR SERIOUS INJURY.

## WEAR PROPER ATTIRE

Safety glasses are recommended and must be worn if any roof cutting or scraping is being done in the vicinity. Safety glasses and or face shield are also necessary when working with hot stuff.

Wear properly fitting clothes. Tight clothing can restrict movement and slow down reaction time in a dangerous situation.

Loose fitting clothing can be dangerous and cause serious injury if it gets caught in moving mechanical parts. Wear a long-sleeved shirt, buttoned at the cuffs, safety shoes, and pants without cuffs, and knit wrist type gloves.

A hard hat must be worn by operator when working on a job site.

## ROOF PREPARATION

### INSPECT ROOF DECK

Before allowing equipment and personnel access to roof, make certain roof is strong enough to support the weight. Check load limits of deck with owner, builder or architect. Clear the work area of all potentially dangerous obstacles that could cause personal injury to the operator or others. Keep unauthorized people away from construction area. Check to see that all roof openings are guarded to protect against falls.

### WARNING LINE SYSTEM

When operating parallel to roof edge warning line system must be at least six feet from edge. When operating perpendicular to edge warning line must be ten feet from roof edge.



# HOISTING MACHINE TO ROOF

**WARNING: ALWAYS CHECK DECK LOAD LIMITS WITH BUILDER, OWNER, OR ARCHITECT BEFORE DECIDING TO USE ON THE ROOF.**

## INSPECT THE HOIST

Make certain hoist is in safe operating condition, to be operated by trained personnel. The hoist should be clear of ground objects and overhead obstacles, such as power lines; it should be secure and properly counterbalanced. Hoist should be inspected for frayed cables, bent frame members or faulty mechanical parts. Make sure everyone on the ground is completely clear of the hoisting area. Do not exceed the weight and size capacity of your hoist. Do not use if you are in doubt.

## CONNECTING TO LIFT RINGS

One hoist ring is provided on top of the Voyager frames as shown in Fig. 2 and Fig. 3. Connect hook from hoist line to this ring when lifting the Voyager. The tanks must be chained to Voyager to prevent any injury from happening. The hand torch must be strapped to Voyager. Make certain hand torch and tanks are secured before hoisting. Always inspect ring for wear or damage and make sure the hoist, cable, hook, etc. are in good running order or damage or injury may result.



Fig.2



Fig.3

**WEIGHT :**

220 000 (one tank carrier)  
221 000 (two tank carrier)

50 LBS without tank  
75 LBS without tank



## SAFETY PRECAUTIONS

- Do not allow other people to be near the machine during operation (except operator)
- Do not hoist the Voyager 2 with only one tank.
- Never operate equipment that is damaged in any way. Repairs or replacement of damaged components must be made by a qualified mechanic
- Do not modify the equipment. Do not operate a modified piece of equipment.
- Avoid slick areas on the roof to prevent slipping.
- Wear safety footwear and snug fit clothing.
- Be trained to do the specific job before operating the equipment on an actual job.
- Do not exceed weight carrying capacity of the deck. Check with owner or architect for deck capacity.
- Use on flat, level roofs only.
- Guard all openings in the roof.
- Do not operate within 10 feet of roof edge (or within 6 feet, if operation is parallel to the edge.)
- Do not operate this machine if you are under the influence of alcohol, marijuana, or drugs that could impair judgment and ability.
- Keep the equipment in good condition.

**WARNING: KEEP CHAINS AROUND TANKS AT ALL TIMES, WHEN YOU HAVE PROPANE TANKS ON THE VOYAGER**



**WARNING: NEVER PULL THE VOYAGER AS YOU NEED TO SEE WHERE YOU ARE GOING AND AT THE SAME TIME KEEP AN EYE ON THE PROPANE TANK(S)**



## OPERATION

### BEFORE OPERATION

**WARNING: OPERATION WITHOUT CHAINS COULD CAUSE SERIOUS PERSONAL INJURY. DO NOT OPERATE WITH DAMAGED CHAINS, OR WITH BROKEN WELDS.**

Inspect the Voyager before use; look for cracks in welds, broken or loose parts. Make certain chains are in place and fastened securely. Check chains for cracks, broken welds and other damage. Repair or replace if damaged. Never operate when damaged.

The tanks must be chained to Voyager. Strap the hand torch securely. Propane tanks must be handled safely and with care, for more information ask your propane bottle supplier or manufacturer.

**WARNING: NEVER LIFT THE VOYAGER 2 WITH ONLY ONE TANK. ALWAYS LIFT VOYAGER 2 EITHER WITH TWO TANKS OR WITHOUT ANY TANKS OR ELSE INJURIES MAY OCCUR.**

**WARNING: TANKS MUST BE CHAINED TO VOYAGER AND THE HAND TORCH MUST BE STRAPPED TO VOYAGER TO PREVENT FROM BOUNCING OR FALLING FROM VOYAGER WHEN LIFTING. SECURE THE CHAINS BEFORE LIFTING.**

1. Always wear proper clothing (100% cotton is best) as recommended by roof association when on roof.
  - a) Hard hat with face shield
  - b) Long sleeve work shirt buttoned at the wrist and collar
  - c) Long work pants with no cuffs
  - d) Safety high top shoes
  - e) Work gloves with knit wrist (to prevent hot material from spilling into the glove)
2. Be sure Voyager is secure.
3. Use Voyager only on a flat, level roof and within a perimeter warning system.
4. Keep an approved fire extinguisher available in case of fire.
5. Inspect Voyager for any damage and do not use if you suspect damage.



## MAINTENANCE

Lubrication recommendations are as follows: roller bearings on the wheels are pre-lubricated and require no greasing. Replace worn or broken parts before operating.

Tire Servicing: Check tire pressure on tires.

Always check tire manufacturer's recommendations for correct tire pressure before inflating tire. (Correct tire pressure should be imprinted on the side of the tire.)

## SAFETY HAZARDS

Safety hazards are not always obvious to workers. Unlike exposure to health hazards, where illness or injury develop slowly, safety hazards usually result in immediate injury or death.

Broken bones, cuts bruises, sprains, burns and loss of limbs, eyesight and hearing are the kinds of injuries caused by safety hazards.

The rate of occupational injuries in roofing, in fact, ranks in the top ten of all major occupational groups.

### FALLS

Falls are the number one cause of serious injury and death to roofers. An estimated 10 percent of all roofing accidents result from falls off roof edges, through roofing openings or off ladders, more than half of the non-fatal accidents result in serious injury.

Unprotected and unguarded roof edges and roof openings create extremely hazardous conditions.

Ladders with cracked, loose or missing steps: with side rails broken or cracked and not attached firmly to the steps; with broken, loose or missing locks, or coated with grease, oils or hardened bitumen can lead to serious injury. Ladders should always be inspected to make sure they're properly maintained and constructed and that they're long enough to extend three feet above the roof's surface.

Improperly balanced or unstable hoists overturn and will often carry the worker along. Rolls of roofing felt should never be used as counterweight. Workers should know the load capacity; it should be posted.

### BURNS

Skin contact with hot asphalt and hot coal tar pitch usually results in second and third degree burns. They usually involve deeper portions of the skin and are easily infected.

An estimated 16 percent of all injuries are burns from hot stuff. The major causes of burns have been from:

Kettle flashes

- Kettle splashes from dropping pieces of coal pitch or asphalt into the kettle
- Slips and trips while carrying hot bitumen in open containers
- Splashes involving transfer operations like from the hot pipe outlet to a hot lugger, from a hot lugger to a mop cart or a pail, or from the kettle to a pail.

### HEAVY LIFTING

Sprains and strains, a majority of which involve the back, are the most common roofing injury and one of the most severe. Almost 30 percent of these injuries result in 10 or more days away from work.





## FIRE/EXPLOSION

Two conditions must be met in order for fires and explosions to occur. First, there must be an ignition source, a welding arc, spark, cigarette, flame or simply a hot spot as in a kettle or tanker. Secondly, there must be the right mixture of vapours (from asphalt, pitch, solvents) and oxygen.

For kettles and tankers, fire/explosion conditions arise when:

- oversized burners are used to fire the kettle, causing localized overheating of the heating tubes creating a hot spot
- the temperature of the bitumen is brought up to the desired operation temperature too quickly allowing the level of bitumen to drop to the level of the firing tubes, allowing excessively high surface temperatures
- heating the bitumen to its flash point (for asphalt, about 525°-540°; for pitch, about 450°-475°)
- the temperature of the bitumen is hot enough to reach the auto-ignition level
- in tankers, the vent pipe is clogged or plugged so that flammable vapours can build up to explosive levels

Many solvents evaporate quickly at roof temperatures. Explosive mixtures of vapours can be readily formed within confined spaces like high parapet walls, in atriums or in any space where little or no ventilation exists. And any kind of spark or flame can ignite the vapours.

## ELECTROCUTION

Low voltage electricity can cause shock, muscle contractions, breathing difficulty, irregular heartbeat, severe burns and death. The route that the current takes through the body affects the degree of injury. Current flowing from one finger to another would not pass vital organ, while from one hand to another would pass through the heart and lungs.

Electrical tools should be properly grounded. The electrical cord should end in a three-prong grounding contact, or the wires should be enclosed in a metal case with a special grounding attachment.

Employers are required to provide ground fault circuit interrupters for all outlets on construction sites that are not part of the permanent wiring of the building. This is actually a fast-acting circuit breaker, which can shut off electricity in a fraction of a second.

Aluminum or other metal ladders pose a serious electrical hazard around electrical equipment and energized lines.

## FALLING OBJECTS

Tools, bricks, materials, buckets, boxes, pallets or almost anything dropped from a sufficient height can cause severe damage. Head injuries, one of the highest compensated injuries to workers, often include brain damage. Workers need protective head gear when working beneath people, tools and equipment.

## FLYING OBJECTS

Objects can be projected by machines, from welding or grinding operations and can be windblown. Tear-off operations, where power cutters, power brooms and power spudders are generally used, are the major source of flying substances. The part of the body most often injured is the eyes.

## UNGUARDED MACHINERY

Exposed blades and chains on powered machinery like hoists and roof cutters can severely lacerate and crush parts of the body. Guards should always be fitted over moving parts to protect workers.

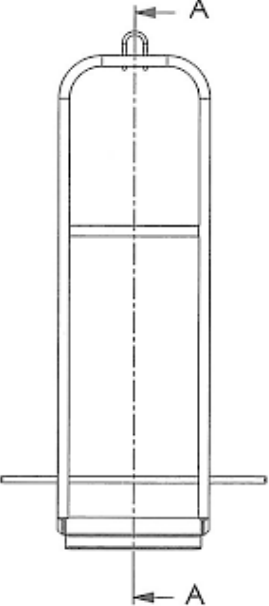

**LIFTING CERTIFICATE - 220 000 (FRENCH ONLY)**

FABRIQUER TEL QUE DESSINS ENVOYÉS LE 05-06-2009



CAPACITÉ MAXIMALE DE LEVAGE PAR L'ANNEAU SUPÉRIEUR D'UNE BOUTEILLE PLEINE AYANT UN POIDS TOTAL DE 250LBS

LORSQUE BOSSÉ OU CROCHE L'ÉQUIPEMENT DOIT ÊTRE REMIS DANS SON ÉTAT INITIAL POUR AVOIR LA CAPACITÉ MENTIONNÉE.

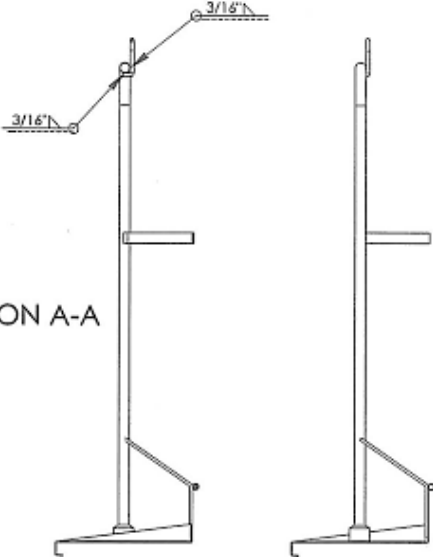

SECTION A-A



NE PAS MESURER SUR LE DESSIN	SAUF INDICÉ, DIMENSIONS EN POUCE			Titre: DESSIN D'APPROBATION POUR VOYAGEUR 1 (#220000)
	12-06-09 APPROBATION CAPACITÉ JFM # DATE DESCRIPTION/RÉFÉRENCE PAR		256, rue Montpelier, Longueuil, Qc J4L 4P3 (514-247-8916 ext. 470-616-1797)	183-2009-06-02 1 de 1 JFMC 12-05-2009 NA
RÉVISIONS			J.F. McCutcheon Ing. J.F. McCutcheon Ing.	



# LIFTING CERTIFICATE - 221 000

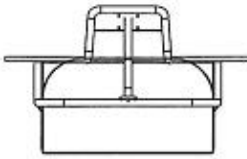

TO BE CONSTRUCTED AS DRAWINGS SENT ON JUNE, 05 2009

TO BE LIFTED BY THE TOP "U" BRACKET.

LIFTING DEVICE (SLING, ROPE...) MUST BE APPLIED TO THE TOP "U" BRACKET ON AT LEAST 1/2" WIDE WHEN LIFTING.

MAXIMUM LIFTING CAPACITY OF TWO (2) FILLED BOTTLES (250LBS TOTAL EACH)

EVERY COMPONENTS MUST BE MADE OF 44W STEEL GRADE

WHEN THE EQUIPMENT HAVE ANY MECHANICAL DAMAGE IT MUST BE RESTORED TO ITS INITIAL CONDITION TO HAVE THE APPROVED LIFTING CAPACITY.

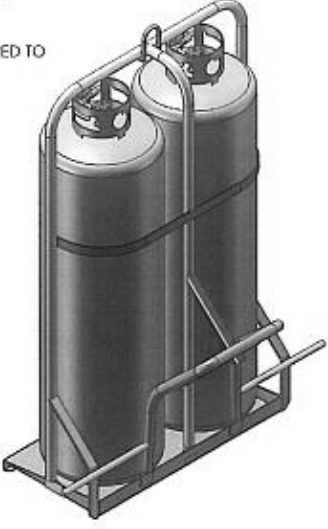

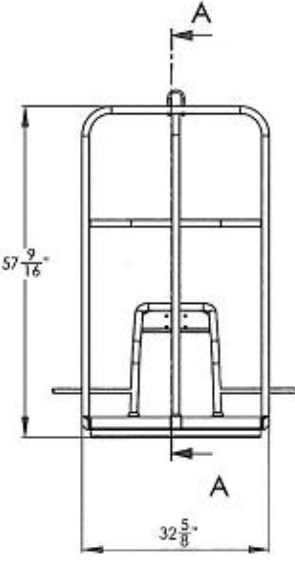

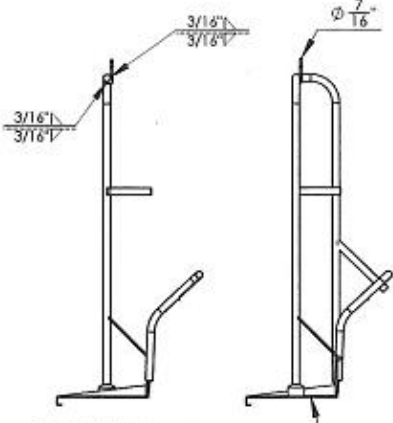





SECTION A-A

MUST BE MADE OF 3/16" 44W STEEL

DO NOT MEASURE ON DRAWING	WITHOUT INDICATION DIMENSIONS ARE INCHES		 <p><b>JFMC Inc.</b> 555, rue Mercier, Longueuil, Qc, J4L 4P3 Tél: 514-247-2009 Fax: 438-436-1717</p>	Client: TITRE: APPROBATION DRAWING VOYAGEUR 2 (#221000) Date: 183-2009-05-04B 1 of 1 Catégorie: JFMC Date: 24-09-2009 Code: NA
	# DATE DESCRIPTION BY 24-09-03 CAPACITY APPROBATION JFM # DATE DESCRIPTION BY RÉVISIONS		Drawn by: J.F. McCutcheon Ing. Checked by: J.F. McCutcheon Ing.	

