



410 000

## G41 MINI-LOADER

How about a machine that can pick-up, push, sweep, tear-off, carry, move, dump, lift, dig, etc... and do it safely with minimal maintenance.

The G41 is the lightest machine in its class, while being very powerful. Its CH20S Kohler engine offers tons of torque and a 2 year commercial warranty.



It is also equipped with a universal attachment adaptor that allows the use of dozens of accessories.

The G41 features 4 independent hydraulic wheel motors that require no chains, and therefore no adjustments nor tensioning of these chains, eliminating the lag from loose chains. The controls



keep their precision and the operator keeps working, reducing down time.

Safety is enhanced by placing the operator on a platform at the back of the machine, allowing the operator to "Step-off" in case on an emergency.

The operator's feet are also protected from the machine's moving wheels and ergonomic levers permit comfortable and precise use of the controls.

This configuration also keeps the bucket away from the operator, keeping falling debris away from the operator's hands and head.

Maintenance is made easy by putting everything within reach.

[SEE THE BACK](#)

This machine was designed with exceptional access to all components for ease of maintenance, all fittings, hoses, filters, etc. are accessible from the top, the sides or the back.

- 4 independent wheel motors, no chains, no adjustments, no lag in the operation of the controls due to loose chains, this is a real 4 wheel drive.
- CH20S Kohler engine with tons of torque and 2 year commercial warranty!
- Removable dash for easy access to fittings and components.
- Master valve contains a float on the lift section as a standard.
- Floating excavator control levers, standard.
- Auxiliary valve with flow control to allow 0-12 GPM adjustment.
- Standard hour meter with reset and RPM.
- Large capacity gasoline tank, 30L (8 gal.) for prolonged working periods and removable for those times when emptying is required.
- Removable lateral storage box.
- Cylinder lock bar to allow safe maintenance of the machine under the arms.
- Flat bottom so going over obstruction, won't snag or damage hydraulic hoses or other components.
- Universal attachment adaptor and flat face quick couplers allow the use of dozens of accessories.
- 4 lifting rings to lift and/or secure the machine.
- Many different styles of wheels available as options.

**Tipping capacity: 1000 lbs**

**Rated operating capacity: 500 lbs (50% of tipping capacity)**

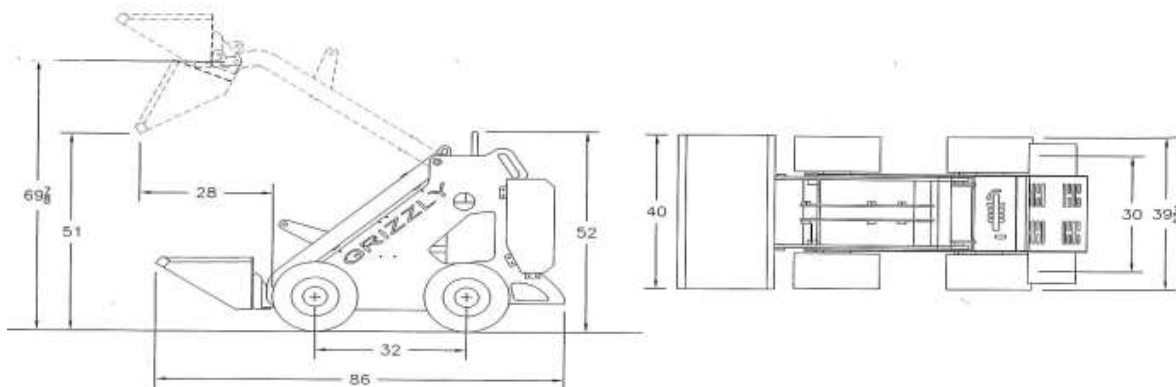

Optional wheels

